



# i-Start AC Motor Soft Starter User Information & Installation Guide

## Product Description:

i-Start is a small electronic AC motor soft-starter designed for any Permanent Split Capacitor (PSC) Motor of up to 4.5kW (6HP) output.

Its primary purpose is to reduce the current drawn by the motor at start-up to below the 45 Amps specified by regulatory authorities. This results in lower power consumption at start-up, reduced acoustic noise and significantly less 'light flicker' when the motor starts. The unit also features 'under-voltage' protection, which disables the attached motor in the event of mains power outages, power 'brown-outs', or hardware failure.

The overall result is superior motor protection, greater reliability and extended motor life, all at a very low price.

## Specification:

Motor type:	Permanent Split Capacitor (PSC) motors
Motor range:	Up to 4.5kW (6HP) (do not exceed RLA).
Operating voltage:	200-265VAC
Motor Rated Load Current (RLA) max:	32Amps

## Installation and Connection:

### Warnings

- Only to be installed by **qualified service personnel**.
- For installation in a **weatherproof enclosure**.
- **Hazardous voltages** are present on all terminals of the i-Start therefore installation should be in Service Access areas only.
- Ensure all **connections are correct and tight** before energising the unit. Incorrect connection may result in damage to the i-Start and/or the motor.
- Allow the Run Capacitor to **discharge** for 5 minutes AND test for safe voltage, after power has been isolated from the **installation before handling the Run Capacitor terminals**.

### Connection Diagrams:

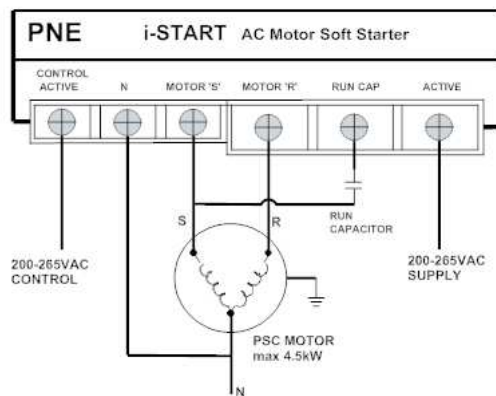

**Master Operation Wiring Diagram**

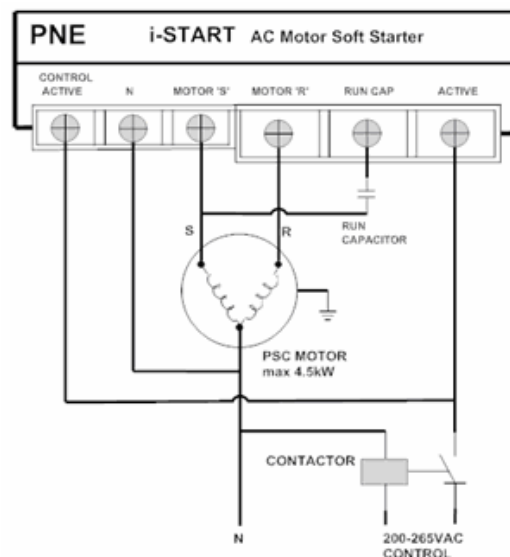

**Slave Operation Wiring Diagram**



## Functions:

### 1 - Master/Slave Operation

When the i-Start is installed between a motor and the mains supply, the i-Start acts as the Master starter. Alternately, it may be installed between a motor and a contactor to act as a Slave (by switching the mains supply to both the Active and Control Active at the same time via a contactor).

### 2 - Random Start Delay

When power is first returned after a power outage, many devices will normally start-up at the same time resulting in a large fluctuation to the mains supply. To avoid contributing to and/or being affected by this issue, the i-Start applies a random start delay of between 3 and 18 seconds on start up.

### 3 - Auto-Optimise motor configuration

The Soft Starter automatically optimises its start period to suit the motor it is controlling, for lowest inrush current and best start performance.

### 4 – Under Voltage Detection

The Soft Starter prevents the motor from starting if the mains voltage is below 200VAC.

Once the motor is operating, the motor is protected against mains under-voltages (ie, voltages below 180VAC) by shutting down and indicating a 'Power Fail' condition.

A re-start delay after power failure prevents excessive number of restarts in areas where the power quality is poor.

## LED Status Indicator:

Status is displayed via the red LED as follows:

- **LED Off**

No power to the i-Start.

There is no power to the Active (Master Operation) or no power to both Active & Control Active (Slave Operation).

- **LED On**

Normal operation, when the i-Start has power and the attached motor has started and is running.

- **One flash every 5 seconds**

Normal operation the i-Start has power, but the Soft Starter is in the *Off* mode. The Control Active is *OFF* (Master Operation).

- **On-Off flash (50%)**

The unit is performing its start delay. This will be between 3 and 18 seconds (Master Operation). In Slave operation the start delay will be extended a further 30 seconds.

- **Two Flashes**

Internal fault.

The unit needs to be replaced.

- **Three Flashes**

Power Failure Delay.

The unit has detected a mains power under-voltage or "brown out", has turned the motor off, and is in delay before attempting to restart the motor following recovery of the mains supply to normal voltages.